

# Merus Ring – Water Treatment

## Specification Sheet

### Product

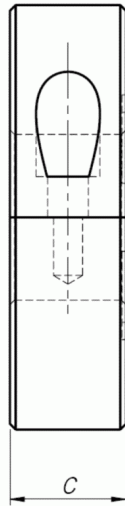
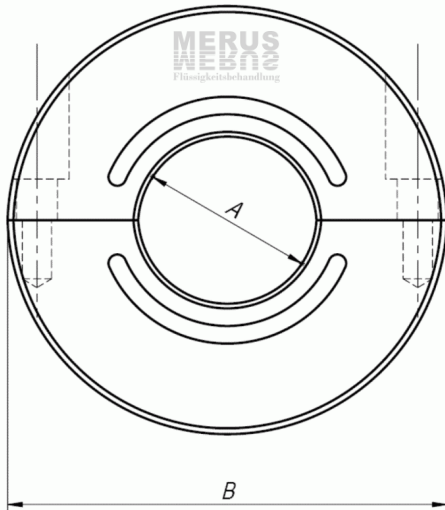

- Origin:** Made in Germany
- Material:** Aluminum-silicon alloy
- Parts:** 2 half-shells, 2 screws
- Size:** Suitable Merus Rings for all common pipe sizes.
- Function:** Increase the solubility of all soluble parts in a liquid. Reduces deposition, corrosion and biofouling.

### Product variants

Product type	Function	Limescale	Corrosion	Biofilm/ Biofouling	Industrial Application	High Capacity
Standard		✓	✓			
Industrial		✓	✓		✓	
Bio Industrial		✓	✓	✓	✓	
High Capacity Industrial		✓	✓		✓	✓
Bio HCl		✓	✓	✓	✓	✓

### Installation

